

Programmable AC Power Supply

IT7300 Series Programming Guide

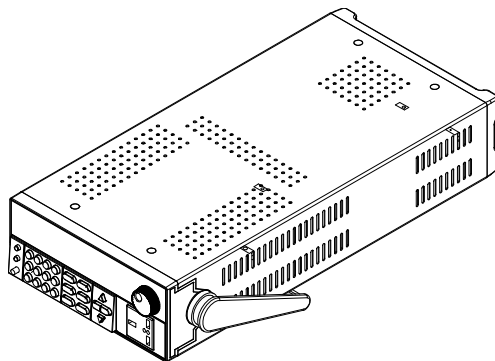

Model:

IT7321/IT7322/IT7322H/IT7324/IT7324H/IT7326/
IT7326H/IT7322T/IT7322HT/IT7324T/IT7324HT/
IT7326T/IT7326HT

Version: V1.0

Statement

© Itech Electronic, Co., Ltd. 2018

No part of this manual may be reproduced in any form or by any means (including electronic storage and retrieval or translation into a foreign language) without prior permission and written consent from Itech Electronic, Co., Ltd. as governed by international copyright laws.

Manual Article No.

IT7300-402210

Revision

Revision 1, published on

Mar. 15th, 2018

Itech Electronic, Co., Ltd.

Trademark Statement

Pentium is a registered trademark of Intel Corporation in the United States.

Microsoft, Visual Studio, Windows and MS Windows are trademarks of Microsoft Corporation in the United States and/or other countries/regions.

Guarantee

Materials in the document are provided *talīs qualīs* and may be changed in future revisions without prior notice. In addition, within the maximum allowable extent of laws, ITECH is not committed to any explicit or implied guarantee for this manual and all information therein, including but not limited to the implied guarantee on marketability and availability for some special purposes. ITECH shall not be responsible for any error or incidental or indirect losses caused by the provision, use or application of this documents and information therein. If some guarantee clauses in other written agreements between ITECH and users are not consistent with clauses herein, those clauses in other written agreements shall prevail.

Technology license

Hardware and/or software in this document cannot be provided without a license and can only be used or copied according to the license.

Restricted permission statement

Restricted permissions of the U.S. government. Permissions for software and technical data which are authorized to the U.S. Government only include those for custom provision to end users. ITECH follows FAR 12.211 (technical data), 12.212 (computer software). DFARS 252.227-7015 (technical data--commercial products) for national defense and DFARS 227.7202-3 (permissions for commercial computer software or computer software documents) while providing the customized business licenses of software and technical data..

Safety Statement

CAUTION

“Caution” signs indicate danger. It is required to pay attention to the contents of these signs during implementation of operations.

The damage to the product or loss of important data may be caused in case of improper operation steps or failure to follow operation steps. Do not continue to implement any improper operation indicated in “Caution” signs when the specified conditions are not fully understood or these conditions are not satisfied.

WARNING

“Warning” indicates danger. It is required to pay attention to the contents of these signs during implementation of operation steps. Personal casualties may be caused in case of improper operation steps or failure to follow these operation steps. Do not continue to implement any improper operation indicated in “Warning” signs when the specified conditions are not fully understood or these conditions are not satisfied.



NOTE

“Instructions” indicates operation instructions. It is required to refer to the contents of these signs during operation steps. These signs are used for providing tips or supplementary information for operators.

Certification and Quality Assurance

IT7300 series programmable AC power supply fully meet all of the technical specification in the manual.

Warranty Service





ITECH Company will provide one-year warranty services for the product materials and manufacturing (excluding the following limitations).











- When warranty service or repair is needed, please send the product to the service unit specified by ITECH Company.
- When the product is sent to ITECH Company for warranty service, the customer must pay the one-way freight to the maintenance department of ITECH, and ITECH will be responsible for return freight.
- If the product is sent to ITECH for warranty service from other countries, the customer will be responsible for all the freight, duties and other taxes.

Limitation of Warranty

- Warranty service does not apply to the damage caused in the following circumstances:
- Damage resulting from customer-wired circuits or customer-supplied parts or accessories;
- Product which has been modified or repaired by the customer;
- Damage caused by the circuit installed by the customer or damage caused by operation of the product in non-specified environment;
- The product model or serial number is altered, deleted, removed or made illegible by customer;
- Damage caused by accidents, including but not limited to lightning, water, fire, abuse or negligence.

Safety Signs

| | | | |
|---|---------------------|---|-------------|
|  | Direct current |  | ON (power) |
|  | Alternating current |  | OFF (power) |

| | | | |
|---|--|---|--------------------|
|  | Both direct and alternating current |  | Power-on state |
|  | Protective earth (ground) terminal |  | Power-off state |
|  | Earth (ground) terminal |  | Reference terminal |
|  | Caution |  | Positive terminal |
|  | Warning (refer to this manual for specific Warning or Caution information) |  | Negative terminal |
|  | A chassis terminal | - | - |

Safety Precautions

The following safety precautions must be observed during all phases of operation of this instrument. Failure to comply with these precautions or specific warnings elsewhere in this manual will constitute a default under safety standards of design, manufacture and intended use of the instrument. ITECH assumes no liability for the customer's failure to comply with these precautions.

WARNING

- Do not use the instrument if it is damaged. Before operation, check the casing to see whether it cracks. Do not operate the instrument in the presence of inflammable gasses, vapors or dusts.
- The power supply is provided with a power line during delivery and should be connected to junction box. Before operation, be sure that the power supply is well grounded. Make sure to use the power cord supplied by ITECH.
- Check all marks on the instrument before connecting the instrument to power supply.
- Use electric wires of appropriate load. All loading wires should be capable of bearing maximum short-circuit of electronic load without overheating. If there are multiple loads, each pair of the load power cord must be carry out the full rated short-circuit output current of the power securely.
- Ensure the voltage fluctuation of mains supply is less than 10% of the working voltage range in order to reduce risks of fire and electric shock.

- Do not install alternative parts on the instrument or perform any unauthorized modification.
- Do not use the instrument if the detachable cover is removed or loosen.
- To prevent the possibility of accidental injuries, be sure to use the power adapter supplied by the manufacturer only.
- We do not accept responsibility for any direct or indirect financial damage or loss of profit that might occur when using the instrument.
- This instrument is used for industrial purposes, do not apply this product to IT power supply system.
- Never use the instrument with a life-support system or any other equipment subject to safety requirements.

CAUTION

- Failure to use the instrument as directed by the manufacturer may render its protective features void.
- Always clean the casing with a dry cloth. Do not clean the internals.
- Make sure the vent hole is always unblocked.

Environmental Conditions

The IT7300 series power supply can only be used indoors or in low condensation areas. The following table shows general environmental requirements for this instrument.



| Environmental conditions | Requirement |
|--------------------------|------------------------------|
| Operating temperature | 0°C-40°C |
| Operating humidity | 20%-80%(non condensing) |
| Storage temperature | -10°C-70 °C |
| Altitude | Operating up to 2,000 meters |
| Installation category | II |
| Pollution degree | Pollution degree 2 |



NOTE

In order to ensure the accuracy of measurement, it is recommended to operate the instrument half an hour after start-up.

Regulation Tag

| | |
|---|--|
|  | <p>The CE tag shows that the product complies with the provisions of all relevant European laws (if the year is shown, it indicates that the year when the design is approved).</p> |
|  | <p>This instrument complies with the WEEE directive (2002/96/EC) tag requirements. This attached product tag shows that the electrical/electronic product cannot be discarded in household waste.</p> |
|  | <p>This symbol indicates that no danger will happen or toxic substances will not leak or cause damage in normal use within the specified period. The service life of the product is 10 years. The product can be used safely within the environmental protection period; otherwise, the product should be put into the recycling system.</p> |

Waste Electrical and Electronic Equipment (WEEE) Directive



Waste electrical and electronic equipment (WEEE) directive, 2002/96/EC

The product complies with tag requirements of the WEEE directive (2002/96/EC). This tag indicates that the electronic equipment cannot be disposed of as ordinary household waste.

Product Category

According to the equipment classification in Annex I of the WEEE directive, this instrument belongs to the "Monitoring" product.

If you want to return the unnecessary instrument, please contact the nearest sales office of ITECH.

Compliance Information

Complies with the essential requirements of the following applicable European Directives, and carries the CE marking accordingly:

- Electromagnetic Compatibility (EMC) Directive 2014/30/EU
- Low-Voltage Directive (Safety) 2014/35/EU

Conforms with the following product standards:

EMC Standard

IEC 61326-1:2012/ EN 61326-1:2013 ¹²³

Reference Standards

CISPR 11:2009+A1:2010/ EN 55011:2009+A1:2010 (Group 1, Class A)

IEC 61000-4-2:2008/ EN 61000-4-2:2009

IEC 61000-4-3:2006+A1:2007+A2:2010/ EN 61000-4-3:2006+A1:2008+A2:2010

IEC 61000-4-4:2004+A1:2010/ EN 61000-4-4:2004+A1:2010

IEC 61000-4-5:2005/ EN 61000-4-5:2006

IEC 61000-4-6:2008/ EN 61000-4-6:2009

IEC 61000-4-11:2004/ EN 61000-4-11:2004

1. The product is intended for use in non-residential/non-domestic environments. Use of the product in residential/domestic environments may cause electromagnetic interference.
2. Connection of the instrument to a test object may produce radiations beyond the specified limit.
3. Use high-performance shielded interface cable to ensure conformity with the EMC standards listed above.

Safety Standard

IEC 61010-1:2010/ EN 61010-1:2010

Content

| | |
|---|-----------|
| Certification and Quality Assurance..... | i |
| Warranty Service | i |
| Limitation of Warranty..... | i |
| Safety Signs | i |
| Safety Precautions | ii |
| Environmental Conditions | iii |
| Regulation Tag..... | iv |
| Waste Electrical and Electronic Equipment (WEEE) Directive..... | iv |
| Compliance Information | v |
| Chapter1 Remote Control | 1 |
| 1.1 Overview | 1 |
| 1.2 SCPI Command Introduction | 1 |
| 1.3 Command Type of SCPI | 1 |
| 1.4 Command Format | 4 |
| 1.5 Data Type | 6 |
| 1.6 Communication Interface | 7 |
| 1.6.1 RS232 Interface..... | 7 |
| 1.6.2 USB Interface..... | 9 |
| 1.6.3 LAN Interface..... | 9 |
| 1.6.4 GPIB Interface | 9 |
| Chapter2 System Commands..... | 11 |
| SYSTem:POSetup..... | 11 |
| SYSTem:VERsion? | 11 |
| SYSTem:ERRor?..... | 11 |
| SYSTem:CLear | 12 |
| SYSTem:REMOte | 12 |
| SYSTem:LOCal | 12 |
| SYSTem:RWLock | 13 |
| SYSTem:BEEPer..... | 13 |
| SYSTem:COMMunicate:GPIB:RDEvice:ADDRes | 13 |
| SYSTem:INTErface..... | 14 |
| SYSTem:PRESet | 14 |
| STATus:QUEStionable[:EVENT]? | 14 |
| STATus:QUEStionable:CONDition? | 14 |
| STATus:QUEStionable:ENABle<Enable value> | 15 |
| STATus:QUEStionable:NTRansition | 15 |
| STATus:QUEStionable:PTRansition | 16 |
| STATus:OPERation[:EVENT]? | 16 |
| STATus:OPERation:CONDition?..... | 17 |
| STATus:OPERation:ENABle..... | 17 |
| STATus:OPERation:NTRansition | 18 |
| STATus:OPERation:PTRansition | 18 |
| STATus:PRESet | 18 |

| | | |
|-----------------|---|-----------|
| Chapter3 | Configuration Commands | 19 |
| | CONFig[:SOURce]:VOLTage[:LEVel]:MINimum | 19 |
| | CONFig[:SOURce]:VOLTage[:LEVel]:MAXimum | 19 |
| | CONFig[:SOURce]:FREQuency:MINimum..... | 19 |
| | CONFig[:SOURce]:FREQuency:MAXimum..... | 20 |
| | CONFig:PROTeCt:CURRent:RMS | 20 |
| | CONFig:PROTeCt:CURRent:RMS:MODE | 21 |
| | CONFig:PROTeCt:CURRent:PEAK | 21 |
| | CONFig:PROTeCt:CURRent:PEAK:MODE | 21 |
| | CONFig:BNC[:PORT][:FUNction] | 22 |
| | CONFig:DIMMer:MODE | 22 |
| | CONFig:LIST:STARt:MODE | 22 |
| | CONFig:MEASure:CURRent:MODE..... | 23 |
| | CONFig:MEASure:CURRent:RANGe..... | 23 |
| | [SOURce:]PROTection:CLEAr | 23 |
| Chapter4 | Frequency Control Commands | 24 |
| | [SOURce:]FREQuency[:IMMediate]..... | 24 |
| Chapter5 | Phase Control Commands | 25 |
| | [SOURce:]PHASe:STARt | 25 |
| | [SOURce:]PHASe:END | 25 |
| | [SOURce:]DIMMer[:PHASe] | 25 |
| Chapter6 | Voltage Control Commands | 27 |
| | [SOURce:]VOLTage[:LEVel][:IMMediate][:AMPLitude]..... | 27 |
| | [SOURce:]RANGe..... | 27 |
| Chapter7 | Output Control Commands | 28 |
| | OUTPut[:STATe] | 28 |
| Chapter8 | TRACe Subsystem Commands | 29 |
| | TRACe:CLEAr | 29 |
| | TRACe:FREE? | 29 |
| | TRACe:POINts..... | 29 |
| | TRACe:FEED..... | 30 |
| | TRACe:FEED:CONTRol | 31 |
| | TRACe:DELay | 31 |
| | TRACe:TIMer | 32 |
| | TRACe:DATA? | 32 |
| Chapter9 | Measurement Commands..... | 34 |
| | FETCh[:SCALar]:VOLTage[:AC]? | 34 |
| | FETCh[:SCALar]:CURRent[:AC]? | 34 |
| | FETCh[:SCALar]:POWer[:AC][:REAL]? | 34 |
| | FETCh[:SCALar]:POWer[:AC]:APParent?..... | 34 |
| | FETCh[:SCALar]:POWer[:AC]:PFActor?..... | 35 |

| | |
|---|-----------|
| FETCh[:SCALar]:FREQuency? | 35 |
| FETCh[:SCALar]:CURRent[:AC]:PEAK? | 35 |
| FETCh[:SCALar]:CURRent[:AC]:PEAK:MAXimum? | 35 |
| MEASure[:SCALar]:VOLTage[:AC]? | 35 |
| MEASure[:SCALar]:CURRent[:AC]? | 36 |
| MEASure[:SCALar]:POWer[:AC][:REAL]? | 36 |
| MEASure[:SCALar]:POWer[:AC]:APParent? | 36 |
| MEASure[:SCALar]:POWer[:AC]:PFActor? | 36 |
| MEASure[:SCALar]:FREQuency? | 37 |
| MEASure[:SCALar]:CURRent[:AC]:PEAK? | 37 |
| MEASure[:SCALar]:CURRent[:AC]:PEAK:MAXimum? | 37 |
| MEASure? | 37 |
| FETCh? | 37 |
| Chapter10 List Operation Commands | 38 |
| LIST:STATe | 38 |
| LIST:RECall | 38 |
| LIST:STEP:COUNT | 38 |
| LIST:REPeat | 39 |
| LIST:STEP:VOLTage | 39 |
| LIST:STEP:FREQuency | 40 |
| LIST:STEP:SLOPe | 40 |
| LIST:STEP:DWELL:UNIT | 41 |
| LIST:STEP:DWELL | 41 |
| LIST:STEP:SD:STATe | 42 |
| LIST:STEP:SD:CONTInue | 42 |
| LIST:STEP:SD:VOLTage | 43 |
| LIST:STEP:SD:SITe | 43 |
| LIST:STEP:SD:TIme | 44 |
| LIST:SAVe:BANK | 44 |
| LIST:RUN:STEP:COUNT? | 45 |
| LIST:RUN:STEP:REPeat? | 45 |
| Chapter11 Maximum Power Point Scanning Commands..... | 46 |
| SWEEp:STATe | 46 |
| SWEEp:RECall | 46 |
| SWEEp:STARt:VOLTage | 46 |
| SWEEp:STEP:VOLTage | 47 |
| SWEEp:END:VOLTage | 47 |
| SWEEp:STEP:TIme:UNIT | 47 |
| SWEEp:STEP:TIme | 48 |
| SWEEp:STARt:FREQuency | 48 |
| SWEEp:STEP:FREQuency | 48 |
| SWEEp:END:FREQuency | 49 |
| Chapter12 Trigger Commands | 50 |
| TRIGger[:IMMEdiate] | 50 |

| | |
|---|-----------|
| TRIGger:SOURce..... | 50 |
| Chapter13 Display Commands..... | 51 |
| DISPlay[:WINDow][:STATE] | 51 |
| DISPlay:TEXT<Reference value>..... | 51 |
| DISPlay:TEXT:CLEar | 51 |
| Chapter14 IEEE488.2 Common Commands..... | 52 |
| *CLS | 52 |
| *ESE | 52 |
| *ESR? | 53 |
| *IDN? | 53 |
| *OPC | 53 |
| *RST | 54 |
| *SRE<Enable value> | 54 |
| *STB? | 54 |
| *TRG | 55 |
| *SAV | 55 |
| *RCL | 56 |
| *WAI | 56 |
| *TST? | 56 |
| *OPT? | 57 |
| Appendixes | 58 |
| Register Description | 58 |

Chapter1 Remote Control

1.1 Overview

This chapter will provide following remote configuration introductions:

- SCPI Command Introduction
- Command type
- Command format
- Data format
- Remote Operation

1.2 SCPI Command Introduction

SCPI is short for Standard Commands for Programmable Instruments which defines a communication method of bus controller and instrument. It is based on ASCII and supply for testing and measuring instruments. SCPI command is based on hierarchical architecture which also known as tree system. In this system, Relevant Command is returned to a common node or root, so that a subsystem is formed.

A part of OUTPut subsystem is listed below:

OUTPut:

SYNC {OFF|0|ON|1}

SYNC:

MODE {NORMal|CARRier}

POLarity {NORMal|INVerted}

OUTPut is the root class keyword, SYNC is the second keyword, MODE and POLarity are the third keyword. Colon(:) is used for separating the command keyword and the next level keyword.

1.3 Command Type of SCPI

SCPI has two types of commands, common and subsystem.

- Common commands generally are not related to specific operation but to controlling overallelectronic load functions, such as reset, status, and synchronization. All commoncommands consist of a three-letter mnemonic preceded by an asterisk: *RST *IDN? *SRE 8.
- Subsystem commands perform specific electronic load functions. They are organized into an inverted tree structure with the "root" at the top. The following figure shows a portion of a subsyste command tree, from which you access the commands located along the various paths.

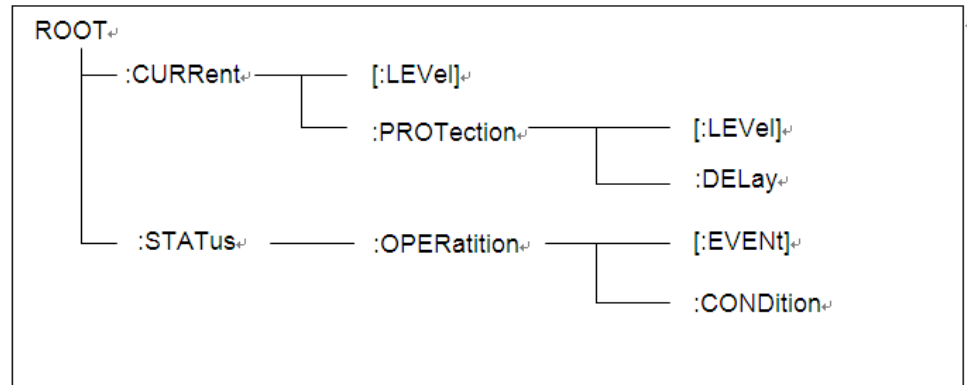

Multiple commands in a message

Multiple SCPI commands can be combined and sent as a single message with one message terminator. There are two important considerations when sending several commands within a single message:

- Use a semicolon to separate commands within a message.
- Head paths influence how the instrument interprets commands.

We consider the head path as a string which will be inserted in front of every command of a message. As for the first command of a message, the head path is a null string; for each subsequent command, the head path is a string which is defined to form the current command until and including the head of the last colon separator. A message with two combined commands: `CURR:LEV 3;PROT:STAT OFF`

The example indicates the effect of semicolon and explains the concept of head path. Since the head path is defined to be "CURR" after "curr: lev 3", the head of the second command, "curr", is deleted and the instrument explains the second command as: `CURR:PROT:STAT OFF`

If "curr" is explicitly included in the second command, it is semantically wrong. Since combining it with the head path will become "CURR:CURR:PROT:STAT OFF", resulting in wrong command.

Movement in the subsystem

In order to combine commands from different subsystems, you need to be able to reset the header path to a null string within a message. You do this by beginning the command with a colon (:), which discards any previous header path. For example, you could clear the output protection and check the status of the Operation Condition register in one message by using a root specifier as follows:

```
PROTection:CLEAr;;STATus:OPERation:CONDition?
```

The following message shows how to combine commands from different subsystems as well as within the same subsystem:

POWER:LEVel 200;PROTection 28; :CURRent:LEVel 3;PROTection:STATe ON

Note the use of the optional header LEVel to maintain the correct path within the voltage and current subsystems, and the use of the root specifier to move between subsystems.

Including Common Commands

You can combine common commands with subsystem commands in the same message. Treat the common command as a message unit by separating it with a semicolon (the message unit separator). Common commands do not affect the header path; you may insert them anywhere in the message.

VOLTage:TRIGgered 17.5;:INITialize;*TRG
OUTPut OFF;*RCL 2;OUTPut ON

Case sensitivity

Common commands and SCPI commands are not case sensitive. You can use upper or lower for example:

```
*RST = *rst
:DATA? = :data?
:SYSTem:PRESet = :system:preset
```

Long-form and short-form versions

A SCPI command word can be sent in its long-form or short-form version. The command subsystem tables in Section 5 provide the in the long-form version. However, the short-form version is indicated by upper case characters. Examples:

```
:SYSTem:PRESet long-form
:SYST:PRES short form
:SYSTem:PRES long-form and short-form combination
```

Note that each command word must be in long-form or short-form, and not something in between.

For example, :SYSTe:PRESe is illegal and will generate an error. The command will not be executed.

Query

Observe the following precautions with queries:

- Set up the proper number of variables for the returned data. For example, if you are reading back a measurement array, you must dimension the array according to the number of measurements that you have placed in the measurement buffer.
- Read back all the results of a query before sending another command to

the electronic load. Otherwise a Query Interrupted error will occur and the unreturned data will be lost.

1.4 Command Format

Formats for command display are as follows:

```
[SOURce[1|2]:]VOLTage:UNIT {VPP|VRMS|DBM}
```

```
[SOURce[1|2]:]FREQuency:CENTer  
{<frequency>|MINimum|MAXimum|DEFault}
```

Based on the command syntax, most commands (and certain Parameter) are expressed in both upper and lower cases. Upper case refers to abbreviation of commands. Shorter program line may send commands in abbreviated format. Long-format commands may be sent to ensure better program readability.

For example, both formats of VOLT and VOLTAGE are acceptable in the above syntax statements. Upper or lower case may be used. Therefore, formats of VOLTAGE, volt and Volt are all acceptable. Other formats (such as VOL and VOLTAG) are invalid and will cause errors.

- Parameter options with given command strings are included in the brace ({}). The brace is not sent along with command strings.
- Vertical stripes (|) separate several parameter options with given command strings. For example, {VPP|VRMS|DBM} indicates that you may assign "APP", "VRMS" or "DBM" in the above commands. Vertical stripes are not sent along with command strings.
- Angle brackets (< >) in the second example indicates that a value must be assigned to the parameter in the brace. For example, the parameter in the angle bracket is <frequency> in the above syntax statements. Angle brackets are not sent along with command strings. You must assign a value (such as "FREQ:CENT 1000") to the parameter, unless you select other options displayed in the syntax (such as "FREQ:CENT MIN").
- Some syntax elements (such as nodes and Parameter) are included in square brackets ([]). It indicates that these elements can be selected and omitted. Angle brackets are not sent along with command strings. If no value is assigned to the optional Parameter, the instrument will select a default value. In the above examples, "SOURce[1|2]" indicates that you may refer to source channel 1 by "SOURce" or "SOURce1" or "SOUR1" or "SOUR". In addition, since the whole SOURce node is optional (in the square bracket), you can refer to the channel 1 by omitting the whole SOURce node. It is because the channel 1 is the default channel for SOURce language node. On the other hand, if you want to refer to channel 2, "SOURce2" or "SOUR2" must be used in the program line.

Colon (:)

It is used to separate key words of a command with the key words in next level.

As shown below:

```
APPL:SIN 455E3,1.15,0.0
```

In this example, APPLy command assigns a sine wave with frequency of 455 KHz, amplitude of 1.15 V and DC offset of 0.0 V.

Semicolon (;)

It is used to separate several commands in the same subsystem and can also minimize typing. For example, to send the following command string:

```
TRIG:SOUR EXT; COUNT 10
```

has the same effect as sending the following two commands:

```
TRIG:SOUR EXT  
TRIG:COUNT 10
```

Question mark (?)

You can insert question marks into a command to query current values of most Parameter. For example, the following commands will trigger to set the count as 10:

```
TRIG:COUN 10
```

Then, you may query count value by sending the following command:

```
TRIG:COUN?
```

You may also query the allowable minimum or maximum count as follows:

```
TRIG:COUN?MIN  
TRIG:COUN?MAX
```

Comma (,)

If a command requires several Parameter, then a comma must be used to separate adjacent Parameter.

Space

You must use blank characters, [TAB] or [Space] to separate Parameter with key words of commands.

Generic commands (*)

Execute functions like reset, self inspection and status operation. Generic commands always start with an asterisk (*) and occupy 3 character sizes, including one or more Parameter. Key words of a command and the first parameter are separated by a space. Semicolon (;) can separate several commands as follows:

```
*RST; *CLS; *ESE 32; *OPC?
```

Command terminator

Command strings sent to the instrument must end with a <Newline> (<NL>) character. IEEE-488 EOI (End or Identify) information can be used as <NL> character to replace termination command string of <NL> character. It is acceptable to place one <NL> after a <Enter>. Termination of command string always resets current SCPI command path to root level.

NOTE

As for every SCPI message with one query sent to the instrument, the instrument will use a <NL> or newline sign (EOI) to terminate response of return. For example, if "DISP:TEXT?" is sent, <NL> will be placed after the returned data string to terminate response. If an SCPI message includes several queries separated by semicolon (such as "DISP?;DISP:TEXT?"), <NL> will terminate response returned after response to the last query. In all cases, the program must read <NL> in response before another command is sent to the instrument, otherwise errors will be caused.

1.5 Data Type

SCPI language defines several data types used for program message and response messages.

- Numerical parameter

Commands requiring numerical Parameter support the notations of all common decimal notations, including optional signs, decimal points, scientific notation, etc. Special values of numerical Parameter are also acceptable, such as MIN, MAX and DEF. In addition, suffixes for engineering units can also be sent together with numerical Parameter (including M, k, m or u). If the command accepts only some specific values, the instrument will automatically round the input Parameter to acceptable values. The following commands require numerical Parameter of frequency value:

```
[SOURce[1|2]:]FREQuency:CENTer {<Frequency>|MINimum|MAXimum}
```

- Discrete parameter

Discrete Parameter are used for settings with limited number of programming values (such as IMMEDIATE, EXTERNAL or BUS). They can use short and long format like key words of commands. They may be expressed in both upper and lower case. The query response always returns uppercase Parameter in short format. The following commands require discrete Parameter in voltage unit:

```
[SOURce[1|2]:]VOLTage:UNIT {VPP|VRMS|DBM}
```

- Boolean parameter

Boolean Parameter refer to true or false binary conditions. In case of false conditions, the instrument will accept "OFF" or "0". In case of true conditions,

the instrument will accept "ON" or "1". In query of Boolean settings, the instrument will always return "0" or "1". Boolean Parameter are required by the following commands:

DISPlay {OFF|0|ON|1}

- ASCII string Parameter

String Parameter may actually include all ASCII character sets. Character strings must start and end with paired quotation marks; and single quotation marks or double quotation marks are both allowed. Quotation mark separators may also act as one part of a string, they can be typed twice without any character added between them. String parameter is used in the following command:

DISPlay:TEXT <quoted string>

For example, the following commands display message of "WAITING..." (without quotation marks) on the front panel of the instrument.

DISP:TEXT "WAITING..."



Single quotation marks may also be used to display the same message.

DISP:TEXT 'WAITING...'

1.6 Communication Interface

IT7300 have four standard communication interfaces: LAN, USB, RS232, GPIB, IT7321 standard with LAN/USB/RS232 communication interface. The customer can choose any one according to his demands.



1.6.1 RS232 Interface

There is a DB9 connector at the rear of the power supply, when connect to computer, you need to select a cable with COM port on both side; To active you need to press  (Shift)+  (Menu) button to enable the settings in menu to be the same with the PC communication configuration. You could do the secondary development with all SCPI commands.





Note

The RS232 settings must match the settings in front panel system information.



If any change, please press  (Shift) +  (Menu) key to modify the menu: SYST SET\COMM.

RS232 data format

RS232 data is a 10-bit word with one start bit and one stop bit. The number of start bit is not programmable. Stop bit is selectable between 1&2. Besides, you

can set the parity bit in the menu using the front panel  (Shift) +  key. Parity options are stored in a non-volatile memory.

Baudrate

The front panel  (Shift) +  (Menu) button allows the user to set baud rate which is stored in the non-volatile memory: 4800,9600,19200,38400, 57600,115200

RS-232 connection

Adopt the RS232 cable with DB-9 interface because the serial port of RS232 can be connected with that of the controller (e.g. PC). The modulating cable of the air-conditioner is not recommended. The pins of plug are shown as the following table.

If your computer is provided with a RS232 interface with DB-25 plug, a cable and a adapter with DB-25 plug (one end) and DB-9 plug (the other end) are required (not the modulating cable of the air-conditioner)



RS-232 plug pins

| Pin number | Description |
|------------|------------------------|
| 1 | No connection |
| 2 | TXD, transfer data |
| 3 | RXD, receive data |
| 4 | No connection |
| 5 | GND, ground |
| 6 | No connection |
| 7 | CTS, clear transfer |
| 8 | RTS, ready to transfer |
| 9 | No connection |

RS-232 Troubleshooting

In case of connection failure of RS232, perform following check:

- Check if the computer and power supply are provided with same Baud rate, parity check bit, data bit and flow control. The power supply shall be configured with one start bit (fixed) and one or two stop bits.
- Just as described in the RS232 connector, appropriate interface cable or adapter shall be adopted. Notes: even if the cable is equipped with right plug, internal wiring may be incorrect.
- The interface cable must be connected to the right serial port (COM1 and COM2) of the computer.

Communication Setup

Please ensure the PC and power supply has the same configuration in the following items.

Baudrate: 9600(4800, 9600, 19200, 38400, 57600, 115200). You could enter the system menu to set the baudrate.

Data bit: 8

Stop bit: 1

Parity bit: (none, even, odd)

EVEN **8 data bits have even parity**

ODD **8 data bits have odd parity**

NONE **8 data bits have no parity**

Native machine address: (0 ~30, factory default is 0)

| | | | |
|-----------|-------------|-------------|----------|
| Start Bit | 8 Data Bits | Parity=None | Stop Bit |
|-----------|-------------|-------------|----------|

1.6.2 USB Interface

Use a cable with two USB ports to connect power supply and PC. You can program through USB interface to achieve all functions of power supply.



The functions of USB488 interface are as follows:

- Interface is 488.2 USB488 interface
- Receive the following request: REN_CONTROL, GO_TO_LOCAL, and LOCAL_LOCKOUT
- When the interface receives MsgID = TRIGGER USBTMC command, it will transmit the TRIGGER command to the function layer.

The functions of power supply's USB488 are as follows:

- receive all SCPI commands
- device is SR1 enabled
- device is RL1 enabled
- device is DT1 enabled

1.6.3 LAN Interface

Press  (Shift) +  (Menu) on the front panel together to access the menu. Select LAN in the Communication from System and then configure Gateway, IP, Mask and SocketPort in the LAN option.

Connect the LAN interface of power supply to the computer with a reticle (crossed).

1.6.4 GPIB Interface

Use a IEEE488 bus to connect GPIB interfaces of power supply and PC. Please ensure that the screws have been screwed down in order to have a full

connection. Then press **Shift** + **Select** (Menu) to enter the system menu, and then select the Communication to set the GPIB address. The address range of power supply is 0 to 30. After you set the address, please press **Enter** button to confirm, GPIB address is saved in nonvolatile memory.

Chapter2 System Commands

SYSTem:POSetup

This command is used to set the system power-on parameter.

Command syntax

SYSTem:POSetup RST|SAV0

Parameters

RST|SAV0

Returns

None

Query syntax

SYSTem:POSetup?

SYSTem:VERsion?

This command is used to query the current SCPI version. The returned parameter is a string like "YYYY.V", in which the YYYY is the year of that version, V is the software version of that year.

Command syntax

SYST:VERS?

Parameters

None

Returns

<NR2>

Example

1991.1

SYSTem:ERRor?

This order is used to query the error information of the power supply. When the error LED lights on the front panel, it tells us that there is one or more hardware or order syntax error happened. There are at most 20 groups of error message.

Send the order once will read one error message from the error queue.

- Error messages follow the FIFO (first-in-first-out) principle. The first error

will be returned first. when you read all the error tips information in the error queue. The ERROR led will turn off. When error occur the buzzer of the power supply will beep once.

- If more than 20 errors occurred, the last one stored in the queue will be replaced by “-350”, Meaning "too many mistakes.". If the error messages in the error message queue are not read out, the error following will not be saved to the queue. If there is no error message, when read error information, it will return “+0”, meaning “no error”.
- If turn off the power supply or send “CLS(clear status) order, the error messages in the error queue will be cleared. *RST order will not clear the error messages in the error queue.

SYSTem:CLEar

This command is used to clear the error information.

Command syntax:

SYSTem:CLEar

Parameters

None

Returns:

None

SYSTem:REMOte

This command is used to set the power to remote control mode. Only the Shift, Local, Select, and On / Off keys are available on the front panel, and all other keys are locked for use. Failure to send this command for remote control configuration before sending control commands using a PC may cause communication errors.

Command syntax

SYST:REM

Parameters

None

Query syntax

None

SYSTem:LOCal

This command is used to switch the instrument to local control

mode(control from panel). In this mode ,all of keys on front panel is valid.

Command syntax

SYST:LOC

Parameters

None

Query syntax

None

SYSTem:RWLock

This command is transmit through interface, the same function as SYST:REM, but the difference is: this command can lock “LOCAL” button as well. When this command is executed, the “Local” button can’t switch to local control mode.

Command syntax

SYST:RWL

SYSTem:BEEPer

This command is used to turn on/turn off the beeper, when the arguments is set to 1/ON, the beeper is enabled and press keyboard will beeper, otherwise, it is mute.

Command syntax

SYSTem:BEEPer

Parameters

OFF|ON|0|1

Example

SYST:BEEP 1

SYSTem:COMMunicate:GPIB:RDEvice:ADDRess

This command is used to set the address of GPIB interface.

IT7321 instrument has no GPIB interface, so the command is only applicable to other models.

Command syntax

SYSTem:COMMunicate:GPIB:RDEvice:ADDRess <NR1>

Parameters

0~30

Query syntax

SYSTem:COMMunicate:GPIB:RDEvice:ADDRess?

Returns

0~30

SYSTem:INTerface

This command is used to switch the communication interface. IT7321 does not support GPIB interface.

Command syntax

SYSTem:INTerface <USB|RS232|LAN|GPIB>

SYSTem:PRESet

System reservation command

STATus:QUEStionable[:EVENT]?

This command can be used to read the value in query event register. The power supply will return a decimal number corresponding to the binary weighted sum of each unit digit of register. These digits will be latched. After executing this command, the query event register will be cleared.

Query syntax

STATus:QUEStionable[:EVENT]?

Parameters

None

Returns

<NR1>

Related commands

STATus:QUEStionable:ENABle

STATus:QUEStionable:CONDition?

This command is used to read the value of query condition register to get the power meter's status, such as ocpeak/ ocrms/ ov/op/ot.

Query syntax

STATus:QUEStionable:CONDition?

Parameters

None

Returns

<NR1>

STATus:QUEStionable:ENABLE<Enable value>

This command edits the enable register value of query event. In query, the power supply will return a decimal number representing the binary weighted sum of the enable register.

Command syntax

STATus:QUEStionable:ENABLE <NRf>

Parameters

0~65535

Power on value

Refer to *PSC command.

Example

STATus:QUEStionable:ENABLE 16

Query syntax

STATus:QUEStionable:ENABLE?

Returns

<NR1>

Related commands

*PSC

STATus:QUEStionable:NTRansition

This command set the value of the Questionable NTR (Negative-Transition) register. The register serve as polarity filters between the Questionable Condition and Questionable Event registers to cause the following actions.

When a bit of Questionable NTR register is set to 1, then a 1-to-0 transition of the corresponding bit of the Questionable Condition register causes that bit in the Questionable Event register to be set.

Command syntax

STATus:QUEStionable:NTRansition <NR1>

Parameters

0~65535

Example

STATus:QUEStionable:NTRansition 128

Query syntax

STATus:QUEStionable:NTRansition?

STATus:QUEStionable:PTRansition

This command set the value of the Questionable PTR (Positive-Transition) register. The register serve as polarity filters between the Questionable Condition and Questionable Event registers to cause the following actions. When a bit of Questionable PTR register is set to 1, then a 1-to-0 transition of the corresponding bit of the Questionable Condition register causes that bit in the Questionable Event register to be set.

Command syntax

STATus:QUEStionable:PTRansition <NR1>

Parameters

0~65535

Example

STATus:QUEStionable:PTRansition 128

Query syntax

STATus:QUEStionable:PTRansition?

STATus:OPERation[:EVENT]?

This command can read the parameter from operation event register. After executing this order, operation event register is reset.

Query syntax

STATus:OPERation[:EVENT]?

Parameters

None

Returns

<NR1>

Related commands

STATus:OPERation:ENABLE

Description of the register:

| | | | | | | | | |
|-------|---|---|---|---|---------------------|---|---|---|
| Bit | 7 | 6 | 5 | 4 | 3 | 2 | 1 | 0 |
| Name | N | N | N | N | WTRG SWEEP LIST CAL | | | |
| Value | | | | | 8 | 4 | 2 | 1 |

STATus:OPERation:CONDition?

This command can read the parameter from the operation condition register. When the parameter of operation condition register changes, the bit corresponding in operation event register is 1.

Query syntax

STATus:OPERation:CONDition?

Parameters

None

Returns

<NR1>

STATus:OPERation:ENABLE

This command can set the parameter of operation event enable register. Setting parameter can determine which bit value of operation event register is 1 and the bit will cause OPER of status byte register to be 1.

Command syntax

STATus:OPERation:ENABLE <NR1>

Parameters

0~255

Example

STATus:OPERation:ENABLE 128

Query syntax

STATus:OPERation:ENABLE?

Returns

<NR1>

STATus:OPERation:NTRansition

This command set the value of the Operation NTR (Negative-Transition) register. Setting parameter can determine which bit value of operation event register is 1 and the bit will cause OPER of status byte register to be 1.

Command syntax

STATus:OPERation:NTRansition <NR1>

Parameters

0~255

Example

STATus:OPERation:NTRansition 128

Query syntax

STATus:OPERation:NTRansition?

STATus:OPERation:PTRansition

This command set the value of the Operation PTR (Positive-Transition) register. Setting parameter can determine which bit value of operation event register is 1 and the bit will cause OPER of status byte register to be 1.

Command syntax

STATus:OPERation:PTRansition <NR1>

Parameters

0~255

Example

STATus:OPERation:PTRansition 128

Query syntax

STATus:OPERation:PTRansition?

STATus:PRESet

System reservation command

Chapter3 Configuration Commands

CONFig[:SOURce]:VOLTage[:LEVel]:MINimum

This command is used to configure the voltage lower limit, same as the Volt-Min setting in the instrument panel menu.

Command syntax

```
CONFig[:SOURce]:VOLTage[:LEVel]:MINimum
```

Parameters

MINimum|MAXimum|Float

Example

```
CONF:VOLT:MIN 2
```

Query syntax

```
CONFig[:SOURce]:VOLTage[:LEVel]:MINimum?
```

CONFig[:SOURce]:VOLTage[:LEVel]:MAXimum

This command is used to configure the voltage upper limit, same as Volt-Max setting in the instrument panel menu.

Command syntax

```
CONFig[:SOURce]:VOLTage[:LEVel]:MAXimum
```

Parameters

MINimum|MAXimum|Float

Example

```
CONF:VOLT:MAX 2
```

Query syntax

```
CONFig[:SOURce]:VOLTage[:LEVel]:MAXimum?
```

CONFig[:SOURce]:FREQuency:MINimum

This command is used to configure the frequency lower limit, same as Freq-Min of instrument panel menu.

Command syntax

```
CONFig[:SOURce]:FREQuency:MINimum
```

Parameters

MINimum|MAXimum|Float

Example

```
CONF:FREQ:MIN 60
```

Query syntax

```
CONFig[:SOURce]:FREQuency:MINimum?
```

CONFig[:SOURce]:FREQuency:MAXimum

This command is used to configure the frequency upper limit, same as Freq-Max in the instrument panel menu.

Command syntax

```
CONFig[:SOURce]:FREQuency:MAXimum
```

Parameters

MINimum|MAXimum|Float

Example

```
CONF:FREQ:MAX 400
```

Query syntax

```
CONFig[:SOURce]:FREQuency:MAXimum?
```

CONFig:PROTect:CURRent:RMS

This command is used to configure the current rms protection point. This command is equivalent to Irms-Protect in the front panel menu of the instrument.

Command syntax

```
CONFig:PROTect:CURRent:RMS
```

Parameters

MINimum|MAXimum|Float

Example

```
CONF:PROT:CURR:RMS 2
```

Query syntax

```
CONFig:PROTect:CURRent:RMS?
```

CONFig:PROTect:CURRent:RMS:MODE

This command is used to set current rms protection mode: DELay|IMMEDIATE.

Command syntax

```
CONFig:PROTect:CURRent:RMS:MODE
```

Parameters

DELay|IMMEDIATE

Delay: Enable protection after 1s delay.

IMMEDIATE: Turn on protection now.

Example

```
conf:prot:curr:rms:mod del
```

Query syntax

```
CONFig:PROTect:CURRent:RMS:MODE?
```

CONFig:PROTect:CURRent:PEAK

This command is used to configure the current peak protection point. The command function is equivalent to lpeak-Protect in the instrument panel menu.

Command syntax

```
CONFig:PROTect:CURRent:PEAK
```

Parameters

MINimum|MAXimum|Float

Example

```
conf:prot:curr:peak 3
```

Query syntax

```
CONFig:PROTect:CURRent:PEAK?
```

CONFig:PROTect:CURRent:PEAK:MODE

This command is used to set current peak protection mode: DELay|IMMEDIATE.

Command syntax

```
CONFig:PROTect:CURRent:PEAK:MODE
```

Parameters

DELay|IMMEDIATE

Delay: Enable protection after 1s delay.

IMMEDIATE: Turn on protection now.

Example

```
conf:prot:curr:peak:mod imm
```

Query syntax

```
CONFig:PROTect:CURRent:PEAK:MODE?
```

CONFig:BNC[:PORT][:FUNCTION]

This command is used to set the function of BNC terminal. The command function is the same as BNC-Set in the instrument panel menu.

Command syntax

```
CONFig:BNC[:PORT][:FUNCTION]
```

Parameters

```
I-TRigger|I-RI|O-PHase|O-ON
```

Example

```
CONF:BNC I-RI
```

Query syntax

```
CONFig:BNC[:PORT][:FUNCTION]?
```

CONFig:DIMMer:MODE

The command is used to configure the phase dimming mode: leading/trailing edge dimming. This command function is equivalent to Dimmer in the instrument panel menu.

Command syntax

```
CONFig:DIMMer:MODE
```

Parameters

```
LEADingedge|TRAILingedge|OFF
```

Example

```
conf:dimm:mod lead
```

Query syntax

```
CONFig:DIMMer:MODE?
```

CONFig:LIST:STARt:MODE

This command is used to set the mode that LIST starts to run. The command function is equivalent to the configuration menu to set List-Set.

Command syntax

CONFig:LIST:STARt:MODe

Parameters

ON/OFF|TRIGGER

Query syntax

CONFig:LIST:STARt:MODe?

CONFig:MEASure:CURRent:MODE

This command is used to set the current measurement mode, you can choose automatic or manual mode to measure the current.

Command syntax

CONFig:MEASure:CURRent:MODE

Parameters

AUTO|MANUal

Query syntax

CONFig:MEASure:CURRent:MODE?

CONFig:MEASure:CURRent:RANGE

This command is used to set the current measurement range: High range, Middle range or Low range when the Manual mode is chosen.

Command syntax

CONFig:MEASure:CURRent:RANGe

Parameters

LOW|MIDDLE|HIGH

Query syntax

CONFig:MEASure:CURRent:RANGe?

[SOURce:]PROTection:CLEar

This command is used to clear the protection status. Before that, you need to remove the cause of protection.

Command syntax

[SOURce:]PROTection:CLEar

Chapter4 Frequency Control Commands

[SOURce:]FREQuency[:IMMediate]

This command is used to set the current output frequency of the power supply.

Command syntax

[SOURce:]FREQuency[:IMMediate]

Parameters

MINimum|MAXimum|DEFault|Float

Example

freq 90

Query syntax

[SOURce:]FREQuency[:IMMediate]?

Chapter5 Phase Control Commands

[SOURCE:]PHASE:START

This command is used to set the starting phase angle of the power supply.

Command syntax

[SOURCE:]PHASE:START

Parameters

MINimum|MAXimum|DEFault|Float

Example

phas:star 80

Query syntax

[SOURCE:]PHASE:START?

[SOURCE:]PHASE:END

This command is used to set the termination phase angle of the power supply.

Command syntax

[SOURCE:]PHASE:END

Parameters

MINimum|MAXimum|DEFault|Float

Example

phas:end 80

Query syntax

[SOURCE:]PHASE:END?

[SOURCE:]DIMMER[:PHASE]

This command is used to set the phase angle of the phase dimming function.

Command syntax

[SOURCE:]DIMMER[:PHASE]

Parameters

MINimum|MAXimum|DEFault|Float

Example`dim 120`**Query syntax**`[SOURce:]DIMMer[:PHASe]?`

Chapter6 Voltage Control Commands

[SOURce:]VOLTage[:LEVel][:IMMediate][:AMPLitude]

This command is used to set the output voltage of the power supply.

Command syntax

[SOURce:]VOLTage[:LEVel][:IMMediate][:AMPLitude]

Parameters

MINimum|MAXimum|DEFault|Float

Example

volt:imm 100

Query syntax

[SOURce:]VOLTage[:LEVel][:IMMediate][:AMPLitude]?

[SOURce:]RANGe

This command is used to set the voltage and current range.

Command syntax

[SOURce:]RANGe

Parameters

AUTO|HIGH

Example

rang auto

Query syntax

[SOURce:]RANGe?

Chapter7 Output Control Commands

OUTPut[:STATe]

This command is used to turn on or off the power output.

Command syntax

OUTPut[:STATe] <bool>

Parameters

off|on|0|1

Query syntax

OUTPut[:STATe]?

Chapter8 TRACe Subsystem Commands

The commands in this subsystem are used to configure and control data storage into the buffer.

Note:

These TRACe Subsystem Commands are only used for the single-phase models (IT7321/IT7322/IT7322H/IT7324/IT7324H/IT7326/IT7326H), and the three-phase models (IT7322T/IT7322HT/IT7324T/IT7324HT/IT7326T/IT7326HT) do not apply these commands.

TRACe:CLEar

This action command is used to clear the buffer of readings. If you do not clear the buffer, a subsequent store will overwrite the old readings. If the subsequent store is aborted before the buffer becomes full, you could end up with some “old” readings still in the buffer.

Command syntax

TRACe:CLEar

Parameters

None

TRACe:FREE?

This command is used to read the status of storage memory. After sending this command and addressing the power supply to talk, two values separated by commas are sent to the computer. The first value indicates how many bytes of memory have been stored, and the second value indicates how many bytes of the memory can be stored.

Query syntax

TRACe:FREE?

Returns

<NR1>, <NR1>

Example

TRAC:FREE?

TRACe:POINTs

This command is used to specify the size of the buffer.

Command syntax

TRACe:POINts <NRf+>

Parameters

2 to 1000 | MINimum | MAXimum | DEFault

Example

TRAC:POIN 10

Query syntax

TRACe:POINts? [MINimum|MAXimum|DEFault]

Returns

<NR1>

Related commands

TRAC:FEED

TRACe:FEED

This command is used to select the source of readings to be placed in the buffer. With VOLTage selected, voltage readings are placed in the buffer. With CURRent selected, current readings are placed in the buffer. With TWO selected, voltage and current are placed in the buffer when storage is performed, TRAC:POIN maximum values is 1000.

Command syntax

TRACe:FEED <CRD>

Parameters

VOLTage|CURRent|TWO

Example

TRAC:FEED VOLT

Query syntax

TRACe:FEED?

Returns

<CRD>

Related commands

TRAC:POIN

TRACe:FEED:CONTRol

This command is used to select the buffer control. With **NEVer** selected, storage into the buffer is disabled. When **NEXt** is selected, the storage process starts, fills the buffer and then stops. The buffer size is specified by the **:POINTs** command.

This value must be set to **NEXt** before using the Trace subsystem to query cached data (i.e., execute **TRACe:DATA?**).

Command syntax

```
TRACe:FEED:CONTRol <CRD>
```

Parameters

NEVer | NEXt

Example

```
TRAC:FEED:CONT NEXt
```

Query syntax

```
TRACe:FEED:CONTRol?
```

Returns

```
<CRD>
```

Related commands

```
TRAC:FEED
```

TRACe:DELay

This command is used to set the delay time, which is the time between sending the **TRIGger[:IMMediate]** command (starting to enter the buffering state) and storing the value of the first point. Setting this delay time can be used to prepare for communication with other devices (devices that need to communicate with IT7300).

Command syntax

```
TRACe:DELay <NRf>
```

Parameters

0 to 3600s | MINimum | MAXimum | DEFault

UNIT

S (second)

Example

TRAC:DEL 1

Query syntax

TRACe:DElAy? [MINimum | MAXimum | DEFault]

Returns

<NR3>

TRACe:TIMer

This command is used to set the time interval between two adjacent storage operations, such as the time interval between the second point value and the third point value.

Command syntax

TRACe:TIMer <NRf>

Parameters

0.00002 to 3600s | MINimum | MAXimum | DEFault

UNIT

S (second)

Example

TRAC:TIM 0.1

Query syntax

TRACe:TIMer? [MINimum | MAXimum | DEFault]

Returns

<NR3>

TRACe:DATA?

This command is used to read the readings stored in the cache and return these values to the PC interface.

Before sending this command, you must ensure that the cache function is enabled (i.e. **TRAC:FEED:CONT NEXT** has been executed), and the data buffer of the IT7300 has data storage. Otherwise, the system will report an error by directly running the **TRACe:DATA?** command.

Query syntax

TRACe:DATA?

Returns

{<NR3>}

The following is an example of how to use the commands of the Trace subsystem:

1. TRACe:FREE?

This command is executed to confirm the current buffer status.

2. TRACe:POINts

This command is executed to set the size of the buffer.

3. TRACe:FEED

This command is executed to set the type of reading source saved to the buffer, such as **VOLTage**.

4. TRACe:FEED:CONTRol

This command is executed to set the save mode of the buffer, such as **NEXT**.

5. TRIGger[:IMMEDIATE]

This command is executed to trigger the IT7300 instrument to enter data storage status.

6. TRACe:DATA?

This command is executed to read the data stored in the buffer to the PC interface.

Chapter9 Measurement Commands

FETCh[:SCALar]:VOLTage[:AC]?

This command is used to read the most recent preprocess voltage reading.

Command syntax

```
FETCh[:SCALar]:VOLTage[:AC]?
```

Returns

```
<NR2>
```

FETCh[:SCALar]:CURRent[:AC]?

This command is used to read the latest preprocessing current reading. After this command is issued and the instrument talks, the readings are sent to the PC. This command does not affect the instrument settings, does not trigger the measurement operation, only reads the most recently available readings. This command returns the old readings until a new reading is made.

Command syntax

```
FETCh[:SCALar]:CURRent[:AC]?
```

Returns

```
<NR2>
```

FETCh[:SCALar]:POWer[:AC][:REAL]?

This command is used to read the most recent active power reading.

Command syntax

```
FETCh[:SCALar]:POWer[:AC][:REAL]?
```

Returns

```
<NR2>
```

FETCh[:SCALar]:POWer[:AC]:APParent?

This command is used to read the most recent apparent power reading.

Command syntax

```
FETCh[:SCALar]:POWer[:AC]:APParent?
```

Returns

<NR2>

FETCh[:SCALar]:POWer[:AC]:PFACtor?

This command is used to read the most recent power factor reading.

Command syntax

FETCh[:SCALar]:POWer[:AC]:PFACtor?

Returns

<NR2>

FETCh[:SCALar]:FREQUency?

This command is used to read the most recent frequency reading.

Command syntax

FETCh[:SCALar]:FREQUency?

Returns

<NR2>

FETCh[:SCALar]:CURRent[:AC]:PEAK?

This command is used to read the most recent peak current reading.

Command syntax

FETCh[:SCALar]:CURRent[:AC]:PEAK?

Returns

<NR2>

FETCh[:SCALar]:CURRent[:AC]:PEAK:MAXimum?

This command is used to read the most recent maximum peak current reading.

Command syntax

FETCh[:SCALar]:CURRent[:AC]:PEAK:MAXimum?

Returns

<NR2>

MEASure[:SCALar]:VOLTage[:AC]?

This command is used to read the current voltage output value.

Command syntax

MEASure[:SCALar]:VOLTage[:AC]?

Returns

<NR2>

MEASure[:SCALar]:CURRent[:AC]?

This command is used to read the current current output value.

Command syntax

MEASure[:SCALar]:CURRent[:AC]?

Returns

<NR2>

MEASure[:SCALar]:POWer[:AC][[:REAL]]?

This command is used to read the current output active power value.

Command syntax

MEASure[:SCALar]:POWer[:AC][[:REAL]]?

Returns

<NR2>

MEASure[:SCALar]:POWer[:AC]:APParent?

This command is used to read the current output apparent power value.

Command syntax

MEASure[:SCALar]:POWer[:AC]:APParent?

Returns

<NR2>

MEASure[:SCALar]:POWer[:AC]:PFACtor?

This command is used to read the current output power factor value.

Command syntax

MEASure[:SCALar]:POWer[:AC]:PFACtor?

Returns

<NR2>

MEASure[:SCALar]:FREQuency?

This command is used to read the current output frequency value.

Command syntax

```
MEASure[:SCALar]:FREQuency?
```

Returns

```
<NR2>
```

MEASure[:SCALar]:CURRent[:AC]:PEAK?

This command is used to read the current peak output current.

Command syntax

```
MEASure[:SCALar]:CURRent[:AC]:PEAK?
```

Returns

```
<NR2>
```

MEASure[:SCALar]:CURRent[:AC]:PEAK:MAXimum?

This command is used to read the current maximum peak current.

Command syntax

```
MEASure[:SCALar]:CURRent[:AC]:PEAK:MAXimum?
```

Returns

```
<NR2>
```

MEASure?

FETCh?

This command is used to read the measurement frequency, RMS voltage, RMS current, active power measurement, power factor measurement, apparent power measurement, peak current measurement, maximum peak current measurement.

Parameters

None

Note: The FETCh and MEASure instructions also read various parameter values, except that FETCh reads the last measured value and MEASure is the re-measured value. FETCh speed faster, but the accuracy of MEASure higher.

Chapter10 List Operation Commands

LIST:STATe

This command is used to set the state of list mode.

Command syntax

LIST:STATe

Parameters

DISable|ENABLE

Query syntax

LIST:STATe?

Returns

DISable|ENABLE

LIST:RECall

This command is used to recall a list file.

Command syntax

LIST:RECall <NR1>

Parameters

0~9

Example

LIST:REC 6

LIST:STEP:COUNT

This command sets the number of steps in list file.

Command syntax

LIST:STEP:COUNT

Parameters

1~100

Example

LIST:STEP:COUN 12

Query syntax

LIST:STEP:COUNT?

LIST:REPeat

This command is used to set the running times of list file.

Command syntax

LIST:REPeat

Parameters

1~10000

Example

LIST:REP 100

Query syntax

LIST:REPeat?

LIST:STEP:VOLTage

This command is used to set LIST single-step voltage.

Command syntax

LIST:STEP:VOLTage

Parameter 1

Number of steps, 0 ~ 99

Parameter 2

Voltage, Float, Unit: V

Example

LIST:STEP:VOLT 1,30

Query syntax

LIST:STEP:VOLTage?

Parameters

Number of steps, 0 ~ 99

Example

LIST:STEP:VOLT? 1

LIST:STEP:FREQuency

This command is used to sets the LIST single-step frequency.

Command syntax

LIST:STEP:FREQuency

Parameter 1

Number of steps, 0 ~ 99

Parameter 2

Frequency value, Float

Example

LIST:STEP:FREQ 1,60

Query syntax

LIST:STEP:FREQuency?

Parameters

Number of steps, 0 ~ 99

Example

LIST:STEP:FREQ? 1

LIST:STEP:SLOPe

This command is used to set the LIST single step slope time. Parameters 1 and 2 are mandatory.

Command syntax

LIST:STEP:SLOPe

Parameter 1

Number of steps, 0 ~ 99

Parameter 2

Slope time, Float, Unit: mS

Example

LIST:STEP:SLOP 3,5

Query syntax

LIST:STEP:SLOPe?

Parameters

Number of steps, 0 ~ 99

LIST:STEP:DWELI:UNIT

This command is used to set LIST single-shot delay time unit. Parameters 1 and 2 are mandatory.

Command syntax

LIST:STEP:DWELI:UNIT

Parameters

Number of steps, 0 ~ 99

Parameter 2

Time unit, SEConD|MINUte|HOUR

Example

LIST:STEP:DWEL:UNIT 2,SEC

Query syntax

LIST:STEP:DWELI:UNIT?

Parameters

Number of steps, 0 ~ 99

LIST:STEP:DWELI

This command is used to set LIST single-step delay time. Parameters 1 and 2 are mandatory.

Command syntax

LIST:STEP:DWELI

Parameter 1

Number of steps, 0 ~ 99

Parameter 2

Time value, Float

Example

LIST:STEP:DWEL 3,20

Query syntax

LIST:STEP:DWELI?

Parameters

Number of steps, 0 ~ 99

Example

```
LIST:STEP:DWEL? 3
```

Returns

<NR2>

LIST:STEP:SD:STATe

This command is used to set the surge notch state.

Command syntax

```
LIST:STEP:SD:STATe
```

Parameter 1

Number of steps, 0 ~ 99

Parameter 2

State, DISable|ENABLE

Example

```
LIST:STEP:SD:STAT 3,DIS
```

Query syntax

```
LIST:STEP:SD:STATe?
```

Parameters

Number of steps, 0 ~ 99

Example

```
LIST:STEP:SD:STAT? 2
```

LIST:STEP:SD:CONTInue

This command is used to set whether LIST single-step inrush / notch trigger continuously. Parameters 1 and 2 are mandatory.

Command syntax

```
LIST:STEP:SD:CONTInue
```

Parameter 1

Number of steps, 0 ~ 99

Parameter 2

Status, off|on|0|1

Example

LIST:STEP:SD:CONT 3,on

Query syntax

LIST:STEP:SD:CONTinue?

Parameters

Number of steps, 0 ~ 99

LIST:STEP:SD:VOLTage

This command is used to set the surge / notch voltage of the LIST single-step.

Command syntax

LIST:STEP:SD:VOLTage

Parameter 1

Number of steps, 0 ~ 99

Parameter 2

Surge / Notch Voltage, Float

Example

LIST:STEP:SD:VOLT 3,120

Query syntax

LIST:STEP:SD:VOLTage?

Parameters

Number of steps, 0 ~ 99

LIST:STEP:SD:SITe

This command is used to set the start position of the surge / notch for the LIST single-step. Parameters 1 and 2 are mandatory.

Command syntax

LIST:STEP:SD:SITe

Parameter 1

Number of steps, 0 ~ 99

Parameter 2

Time value, Float, unit: ms

Example

LIST:STEP:SD:SIT 3,20

Query syntax

LIST:STEP:SD:SITe?

Parameters

Number of steps, 0 ~ 99

LIST:STEP:SD:TIME

This command is used to set the surge / notch duration of the LIST single-step.
Parameters 1 and 2 are mandatory.

Command syntax

LIST:STEP:SD:TIME

Parameter 1

Number of steps, 0 ~ 99

Parameter 2

Time value, Float, unit: ms

Example

LIST:STEP:SD:TIM 3,20

Query syntax

LIST:STEP:SD:TIME?

Parameters

Number of steps, 0 ~ 99

LIST:SAVe:BANK

This command is used to store the list file in the specified storage area.

Command syntax

LIST:SAVe:BANK <NR1>

Parameters

0~9

Example

LIST:SAV:BANK 1 //The edited list file is stored in the storage area 1.

LIST:RUN:STEP:COUNT?

This command is used to read the current LIST file running at which step.

Query syntax

LIST:RUN:STEP:COUNT?

Parameters

None

LIST:RUN:STEP:REPeat?

This command is used to read the current LIST repeat times.

Query syntax

LIST:RUN:STEP:REPeat?

Parameters

None

Chapter11 Maximum Power Point Scanning Commands

SWEEp:STATe

This command is used to set the scan function status.

Command syntax

SWEEp:STATe

Parameters

DISable|ENABLE

Example

SWEEp:STATe ENAB

Query syntax

SWEEp:STATe?

SWEEp:RECall

This command is used to invoke the scan file.

Command syntax

SWEEp:RECall <NR1>

Parameters

0~9

Example

SWEEp:REC 4

SWEEp:STARt:VOLTage

This command is used to set the start voltage of the scan function.

Command syntax

SWEEp:STARt:VOLTage <NR1>

Parameters

MINimum|MAXimum|Float

Example

SWEep:STARt:VOLTage 100

Query syntax

SWEep:STARt:VOLTage?

SWEep:STEP:VOLTage

This command is used to set the voltage step of the sweep.

Command syntax

SWEep:STEP:VOLTage <NR1>

Parameters

MINimum|MAXimum|Float

Example

SWEep:STEP:VOLTage 1

Query syntax

SWEep:STEP:VOLTage?

SWEep:END:VOLTage

This command is used to set the termination voltage of the scan function.

Command syntax

SWEep:END:VOLTage <NR 1>

Parameters

MINimum|MAXimum|Float

Example

SWEep:END:VOLTage 5

Query syntax

SWEep:END:VOLTage?

SWEep:STEP:TIME:UNIT

This command is used to set the single-step time unit of the scan function.

Command syntax

SWEep:STEP:TIME:UNIT <NR1>

Parameters

SECond|MINUte|HOUR

Example

SWE:STEP:TIM:UNIT SEC

Query syntax

SWEep:STEP:TIME:UNIT?

SWEep:STEP:TIME

This command is used to set the single-step time of the scan function.

Command syntax

SWEep:STEP:TIME

Parameters

MINimum|MAXimum|Float

Example

SWE:STEP:TIM 3

Query syntax

SWEep:STEP:TIME?

SWEep:STARt:FREQuency

This command is used to set the start frequency of the scan function.

Command syntax

SWEep:STARt:FREQuency

Parameters

MINimum|MAXimum|Float

Example

SWE:STAR:FREQ 50

Query syntax

SWEep:STARt:FREQuency?

SWEep:STEP:FREQuency

This command is used to set the step frequency of the scan function.

Command syntax

SWEep:STEP:FREQuecy

Parameters

MINimum|MAXimum|Float

Example

SWE:STEP:FREQ 1

Query syntax

SWEep:STEP:FREQuecy?

SWEep:END:FREQuecy

This command is used to set the stop frequency of the scan function.

Command syntax

SWEep:END:FREQuecy

Parameters

MINimum|MAXimum|Float

Example

SWE:END:FREQ 50

Query syntax

SWEep:END:FREQuecy?

Chapter12 Trigger Commands

TRIGger[:IMMediate]

This command can generate a trigger regardless of the current trigger mode selection.

Command syntax

TRIGger[:IMMediate]

Parameters

None

Related commands

*TRG TRIG:SOUR

TRIGger:SOURce

This command is used to select the source of the trigger signal. The power supply can receive the trigger signal from the panel (keyboard trigger Trigger key), receive BUS trigger signal or external signal trigger. Trigger source is set to MANUAL trigger when * RST command is executed.

Command syntax

TRIG:SOUR <mode>

Parameters

MANUal|BUS|EXTern

Query syntax

TRIGger:SOURce?

Chapter13 Display Commands

DISPlay[:WINDow][:STATe]

This command is used to turn off or on the VFD display. When the display is off, the output will not be sent to the on-screen display and all lights except the ERROR light will turn off. When the control mode is Local mode, the screen will open automatically. Press Local key to return to the local operation mode from remote control mode.

Command syntax

DISPlay[:WINDow][:STATe] <bool>

Parameters

0|1|OFF|ON

Example

DISPlay 1

Query syntax

DISPlay?

Returns

0|1

DISPlay:TEXT<Reference value>

This command is used to display a message on the front panel display. Up to 12 characters can be displayed in one message, and the extra characters will be ignored. Commas, periods, and semicolons will not be displayed as separate characters, but will be displayed with the previous character.

Command syntax

DISPlay[:WINDow]:TEXT[:DATA]

Query syntax

DISPlay:TEXT?

DISPlay:TEXT:CLEAr

This command is used to clear the information displayed on the front panel.

Command syntax

DISPlay[:WINDow]:TEXT:CLEAr

Chapter14 IEEE488.2 Common Commands

*CLS

This command clears the following registers:

- Standard event register
- Query event register
- Status byte register

Command syntax

*CLS

Arguments

None

*ESE

This command can set the parameter of standard event enable register. Setting parameter can determine which bit of standard event register is 1 and the byte will enable ESB of status byte register is 1.

Command syntax

*ESE <NR1>

Parameters

0~255

Power on value

Refer to *PSC command

Example

*ESE 128

Query syntax

*ESE?

Returns

<NR1>

Related commands

*ESR? *PSC *STB?

***ESR?**

This command can read the value of standard event status register. After executing this command, standard event status register is reset. Bit definition of standard event status register is as the same as the standard event status enable register.

Query syntax

*ESR?

Parameters

None

Returns

<NR1>

Related commands

*CLS *ESE *ESE? *OPC

***IDN?**

This command is used to query related information of AC power.

Query syntax

*IDN?

Arguments

None

Returns

<string>

Example

*IDN?

***OPC**

When all commands before this command are executed, bit OPC in standard event register will be set to 1.

Command syntax

*OPC

Arguments

None

Query syntax

*OPC?

Returns

None

***RST**

This command is used to reset the power to factory default setting.

Command syntax

*RST

Parameters

None

***SRE<Enable value>**

This command sets the condition of the Status Request Enable Register. After executing this command, AC power supply will return back a decimal value which is a binary weighted sum of all bits from the enable register.

Command syntax

***SRE** <NRf>

Parameters

0~255

Power on value

Refer to *PSC command

Example

*SRE 128

Query syntax

*SRE?

Returns

<NR1>

Related commands

*ESE *ESR? *PSC *STB?

***STB?**

This command can read the data from status byte register. After execute this

command, the value of bit6 in status byte register will be clean.

Query syntax

*STB?

Parameters

None

Returns

<NR1>

Related commands

*CLS *ESE *ESR

***TRG**

When the trigger mode of the power supply is BUS order trigger mode, the order will Generates a trigger signal. The function is the same as **TRIGger[:IMMediate]**

Command syntax

*TRG

Parameters

None

Related commands

TRIG TRIG:SOUR

***SAV**

This command will save the current setting value of the power supply to the specified storage area. These parameters include: set voltage, set frequency, start phase, stop phase, output gear and Dimmer phase angle.

Command syntax

*SAV<NRf>

Parameters

0~9

Example

*SAV 3

Related commands

*RCL

***RCL**

This command can recall the setups you saved before from the specified memory.

Command syntax

*RCL<NRf>

Parameters

0~9

Example

*RCL 3

Related commands

*SAV

***WAI**

This command instructs the power supply not to process any further commands until all pending operations are completed. Pending operations are as defined under the *OPC command. *WAI can be aborted only by sending the power supply a device clear command.

Command syntax

*WAI

Parameters

None

Related commands

*OPC

***TST?**

This command is used to query the self-test by the instrument. 0 indicates that self-test succeeds; other Arguments indicate self-test fails. In addition, in case of failure, an error information will be generated to describe failure reason.

Query syntax

*TST?

Parameters

None

Returns

<NR1>

***OPT?**

System reservation command

Appendixes

Register Description

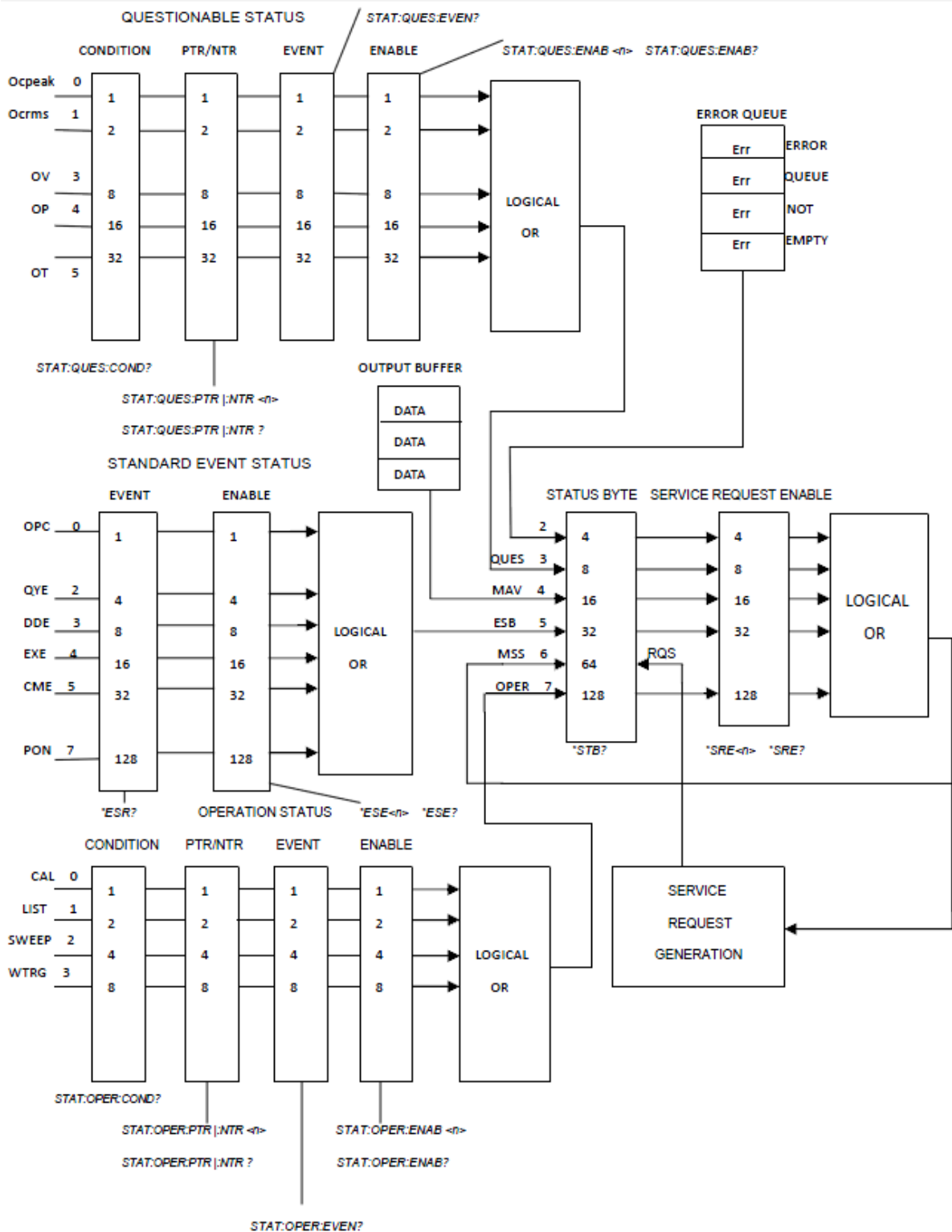

Contact US

Thank you for purchasing ITECH products.If you have any doubt about this product,please contact us as follow.

1. Visit ITECH website www.itechate.com .
2. Select the most convenient contact for further consultation.